

Custom Cupholders

Vertical Mounted Ashtray (VMA2) for minimum 0.50 inch thick panels.*



Inner receptacle rotated closed.

- New, contemporary flat styling.
- Specifically designed for vertical installations.
- Inner receptacle is quickly and easily removed for cleaning.
- Included bezel allows mounting in panels as thin as 0.50 inch thick.*
- Manufactured from aircraft quality 6061-T6 aluminum.
- Standard finish is satin aluminum. (Optional finishes are shown.)



Inner receptacle rotated open.

NOTES:

- P/N - A0.50BLK-3.
- *Some panel dimensions indicated may also require an additional 0.030" thick finish material covering.
- Mounting of ashtray, and the mounting structural requirements, is the responsibility of the installer.
- Some parts shown with optional finishes.



Receptacle removed for cleaning.

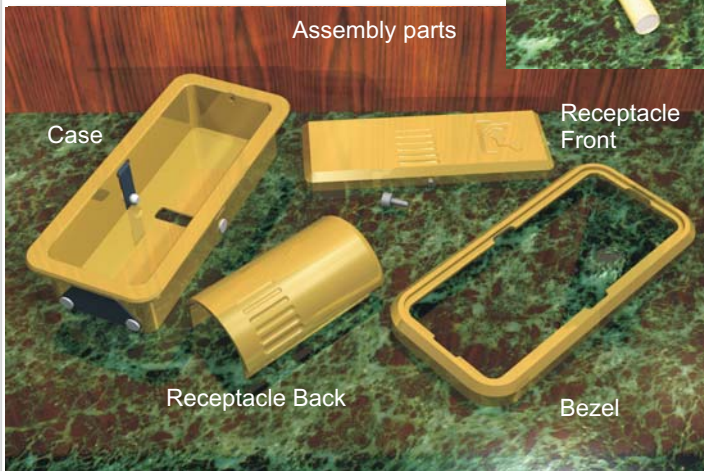

Assembly parts

Case

Receptacle Front

Receptacle Back

Bezel

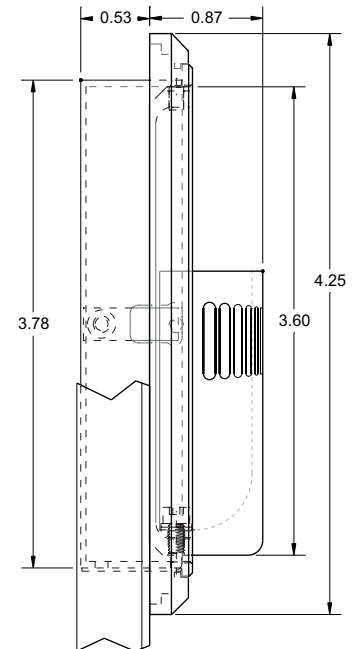

Ashtray shown in open position mounted in 0.50 inch thick vertical panel.*

Finally

elegant interior hardware and accessories for luxury vehicles

P.O. Box 2020, North East, MD 21901, (410) 658-0309 ph (410) 658-0411 fx, www.customcupholders.com

NOTES: 1. MACHINED FROM 6061-T6 ALUMINUM, AMS-QQ-A-200/8.

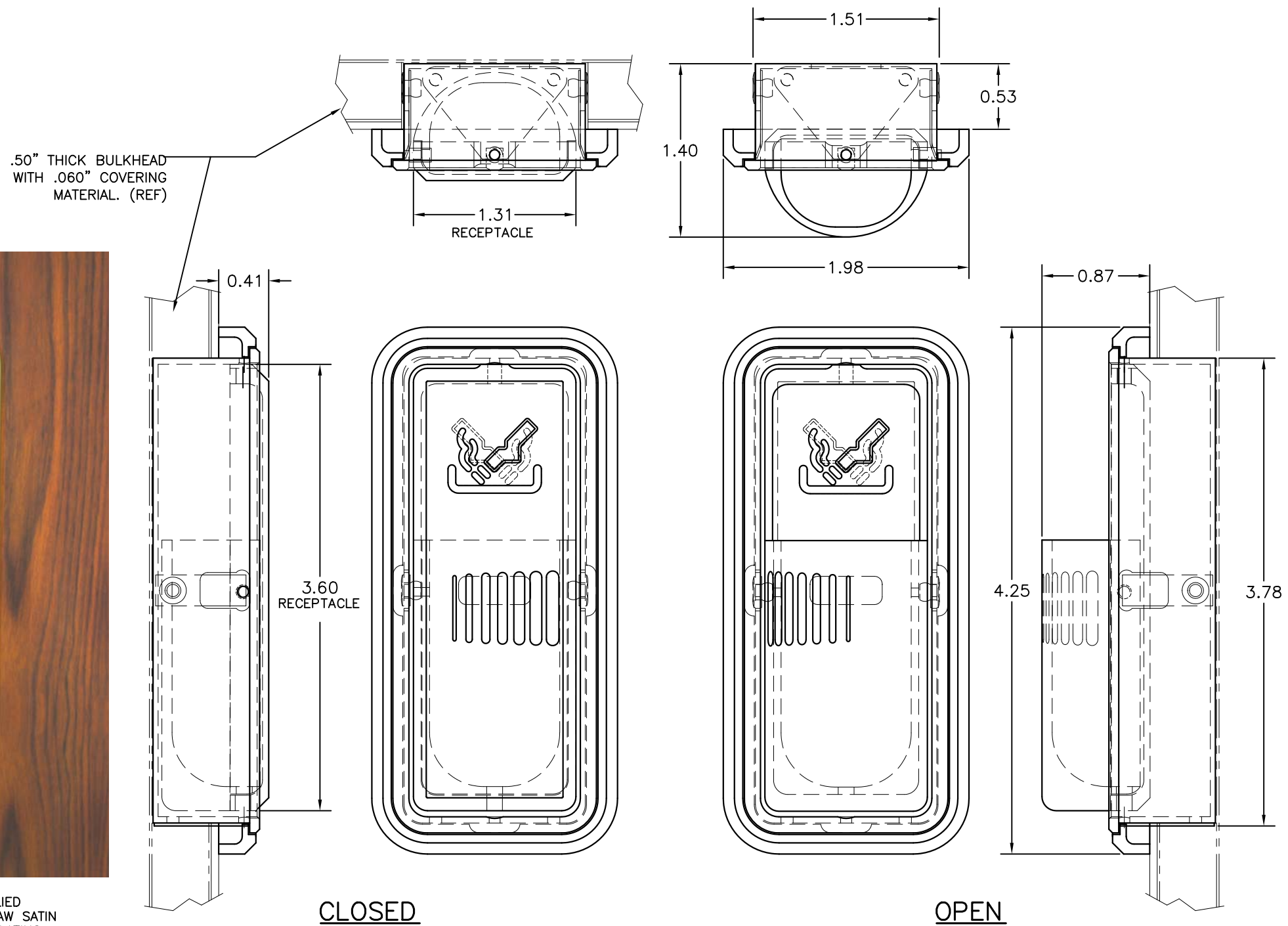

ILLUSTRATION SHOWN WITH A CUSTOMER SUPPLIED ELECTROPLATED FINISH. STANDARD FINISH IS RAW SATIN ALUMINUM READY FOR FINAL POLISHING AND PLATING.



ILLUSTRATION SHOWN WITH A CUSTOMER SUPPLIED ELECTROPLATED FINISH. STANDARD FINISH IS RAW SATIN ALUMINUM READY FOR FINAL POLISHING AND PLATING.

THE DATA OR DESIGNS CONTAINED HEREIN ARE THE EXCLUSIVE PROPERTY OF HORIZON AVIATION GROUP OR CONTAIN PROPRIETARY RIGHTS OF OTHERS AND SHALL NOT BE USED, DISCLOSED, OR COPIED WITHOUT THE WRITTEN CONSENT OF HORIZON AVIATION GROUP.

DECIMAL TOLERANCES (INCHES)
 X.XX = +/- .006
 X.XXX = +/- .002
 ANGLES = +/- .2 DEG.
 RMS FINISH 32

DESIGN	STAFF	DATE	01 MAR 2010	Custom Cupholders Company
DRAWN		DATE		P.O. Box 2020
STRESS		DATE		North East, MD 21901

SCALE: FULL

**VERTICAL MOUNT ASHTRAY
 -2 STYLE (VMA2)**

SHEET: 1 of 1

DRWG # A0.50BLK-3_BASIC

REV: